

## BYPASS SWITCH FOR FREQUENCY INVERTER 16-63 A

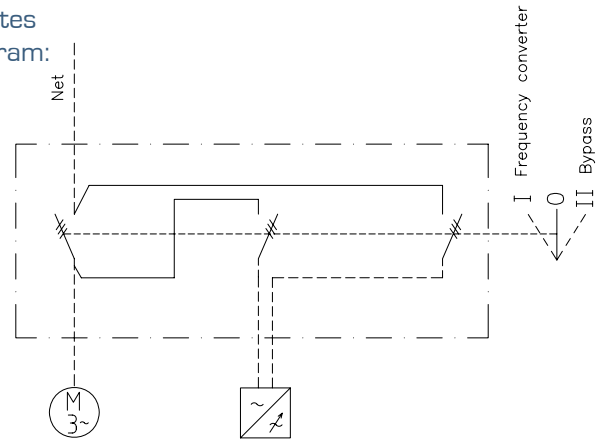

- Polycarbonate (IP 65), sheet steel (IP 65) or aluminium (IP 66) enclosed
- R.M.S value 50kA
- Padlockable
- Door interlock with defeat mechanism
- Tested according to IEC 60 947-3
- CB certificates
- Circuit diagram:



A3

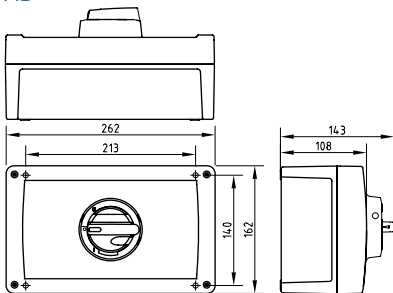

MF11

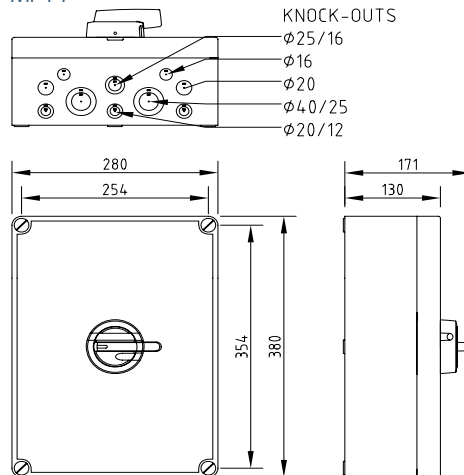

TRO2

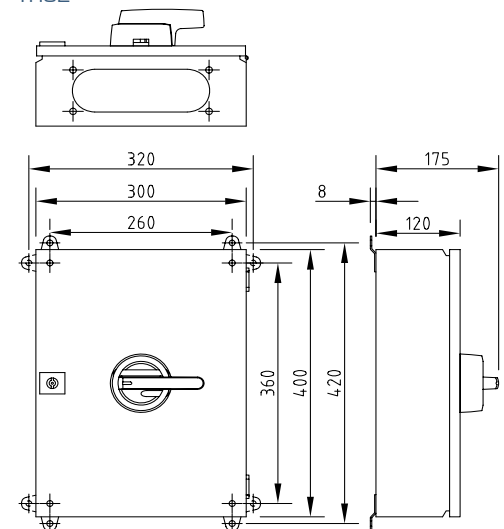

Type	AC-21		AC-22		AC-23	AC-23		EAN-Code	Enclosure	Weight kg	
	400 V 415 V 690 V	I <sub>e</sub> / A	400 V 415 V 690 V	I <sub>e</sub> / A		400 V 415 V 690 V	I <sub>e</sub> / A				P / kW
<b>Polycarbonate enclosures</b>											
KUM 616/316 W.1-0-2 2xKU1.V	40 A		25 A		20 A	7.5 kW	20 A	15 kW	6419410301661	MF11	3,6
KUM 625/325 W.1-0-2 2xKU1.V	63 A		40 A		25 A	11 kW	25 A	22 kW	6419410302057	MF11	3,6
KUM 640/340 W.1-0-2 2xKU1.V	90 A		70 A		50 A	22 kW	32 A	30 kW	6419410302453	MF11	3,6
KUM 663/363 W.1-0-2 2xKU1.V	100 A		80 A		63 A	30 kW	40 A	37 kW	6419410302903	MF11	3,6
<b>Sheet steel enclosures</b>											
KUT 616/316 W.1-0-2 EMC 2xKU1.V	40 A		25 A		20 A	7.5 kW	20 A	15 kW	6419410311509	TRO2	8,5
KUT 625/325 W.1-0-2 EMC 2xKU1.V	63 A		40 A		25 A	11 kW	25 A	22 kW	6419410311554	TRO2	8,5
KUT 640/340 W.1-0-2 EMC 2xKU1.V	90 A		70 A		50 A	22 kW	32 A	30 kW	6419410311608	TRO2	8,5
KUT 663/363 W.1-0-2 EMC 2xKU1.V	100 A		80 A		63 A	30 kW	40 A	37 kW	6419410311653	TRO2	8,5
<b>Aluminium enclosures</b>											
TKA 616/316 W 2xSS EMC	16 A		16 A		16 A	7.5 kW	-	-	6419410311684	A3	3,1